



**MASALTA®**



# **PARTS LIST**

## **SINGLE DRUM**

## **VIBRATORY ROLLER**

## **MSR58 SERIES**



# MAIN ASSEM

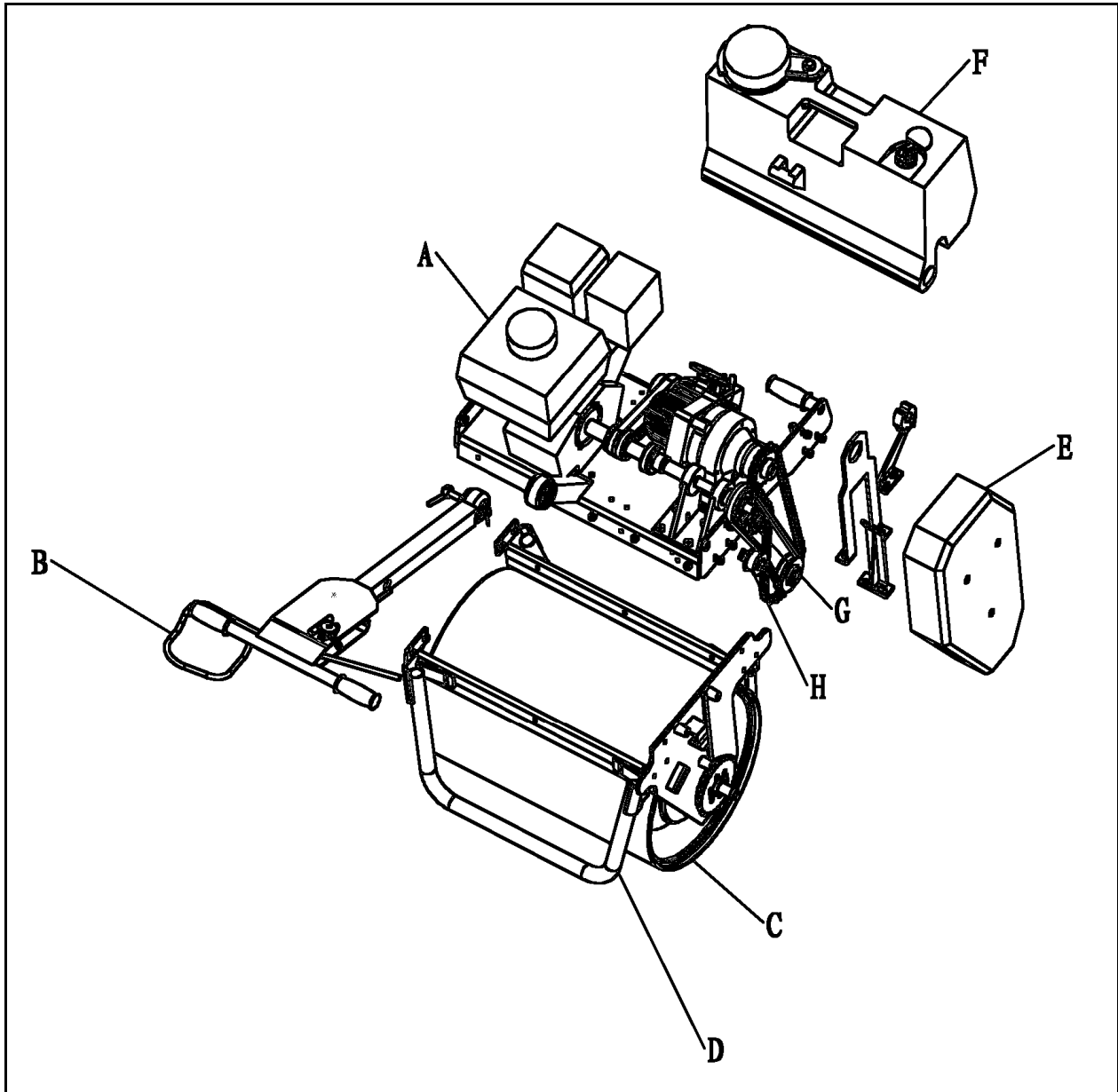

CODE NO.	DESCRIPTION	QTY	REMARK
A	POWER TRANSMISSION	1	
B	HANDLE & BASE PLATE	1	
C	DRUM CPL	1	
D	LOWER FRMAE	1	
E	PROTECTIVE COVER	1	
F	WATER TANK ASSY	1	
G	CHAIN TENSION CPL	1	
H	BELT TENSION CPL	1	

# MSR58 PARTS LIST A — POWER TRANSMISSION

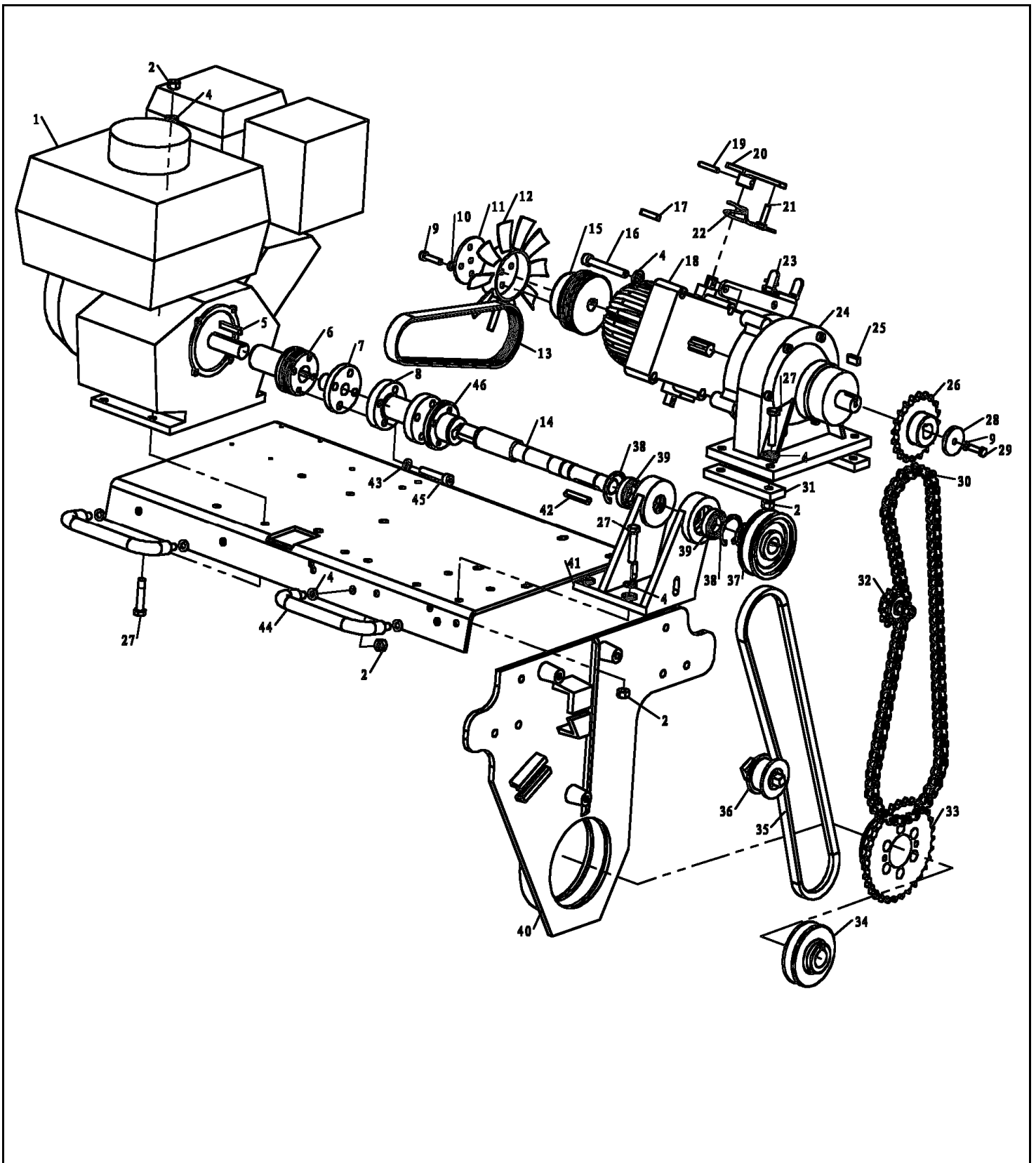

## MSR58 PARTS LIST A — POWER TRANSMISSION

ITEM NO.	PART NO.	DESCRIPTION	QTY	REMARK
1		ENGINE	1	
2	GB889-M8	NUT M8	16	
4	GB97.2-8	FLAT WASHER 8	16	
5	GB1096-5X35	KEY 5X35	1	
6	MYZSK180.00.01.03	PULLEY	1	
7	MYZSK180.00.01.02	COMPRESSION PLATE	1	
8	MYZSK180.00.01.24	CONNECTING ROD	1	
9	GB70.1-M6X25	SOCKET HEAD SCREW M6X25	5	
10	GB93-6	SPRING WASHER 6	6	
11	MYZSK180.00.01.05	PRESSURE PAD	1	
12	MYZSK180.00.01.2	FAN	1	
13	MYZSK180.DQPD	MICRO-V BELT	1	
14	MYZSK180.00.01.09	DRIVING SHAFT	1	
15	MYZSK180.00.01.19	PULLEY	1	
16	GB70.1-M8X60	SOCKET HEAD SCREW M8X60	4	
17	GB1096-5X30	KEY 5X30	1	
18	MYZSK180.CDDY	TRANSMISSION SYSTEM	1	
19	GB879.2	CYLINDER PIN	1	
20	MYZSK180.00.01.21	CONTROL HANDLE	1	
21	MYZSK180.00.01.23	SHAFT	1	
22	MYZSK180.00.01.08	TORSIONAL SPRING	1	
23	MYZSK180.00.01.22	FIXER	1	
24	MYZSK180.JSQ	DECELERATOR	1	
25	GB1096-6X20	KEY 6X20	1	
26	MYZSK180.00.01.15	GEAR, SMALL	1	
27	GB5780-M8X45	BOLT M8X45	12	
28	MYZSK180.00.01.28	PRESSURE PAD	1	
29	GB5780-M6X20	BOLT M6X20	1	
30	MYZSK180.LT	CHAIN	1	
31	MYZSK180.00.01.17	PAD	2	
32	MYZSK180.00.01.20	CHAIN TENSION CPL	1	
33	MYZSK180.00.02.09	GEAR, BIG	1	
34	MYZSK180.00.02.10	PULLEY, SMALL	1	
35	GB11544-1030	V-BELT	1	
36	MYZSK180.00.01.18	BELT TENSION CPL	1	
37	MYZSK180.00.01.29	CLUTCH	1	
38	GB893.1-Φ37	RETAINING RING Φ37	2	
39	MYZSK180.ZC-4	BEARING	2	
40	MYZSK180.00.02.08	BRACKET, RIGHT	1	
41	MYZSK180.00.01.10	BEARING HOUSING	1	
42	GB1096-5X40	KEY 5X40	1	
43	GB97.2-6	FLAT WASHER 6	8	
44	A73E6-42362	LIFTING POINT	2	
45	GB70.1-M6X40	HEX HEAD SCREW M6X40	8	
46	MYZSK180.00.01.27	FLANGE 3	1	

## MSR58 PARTS LIST B — HANDLE & BASE PLATE

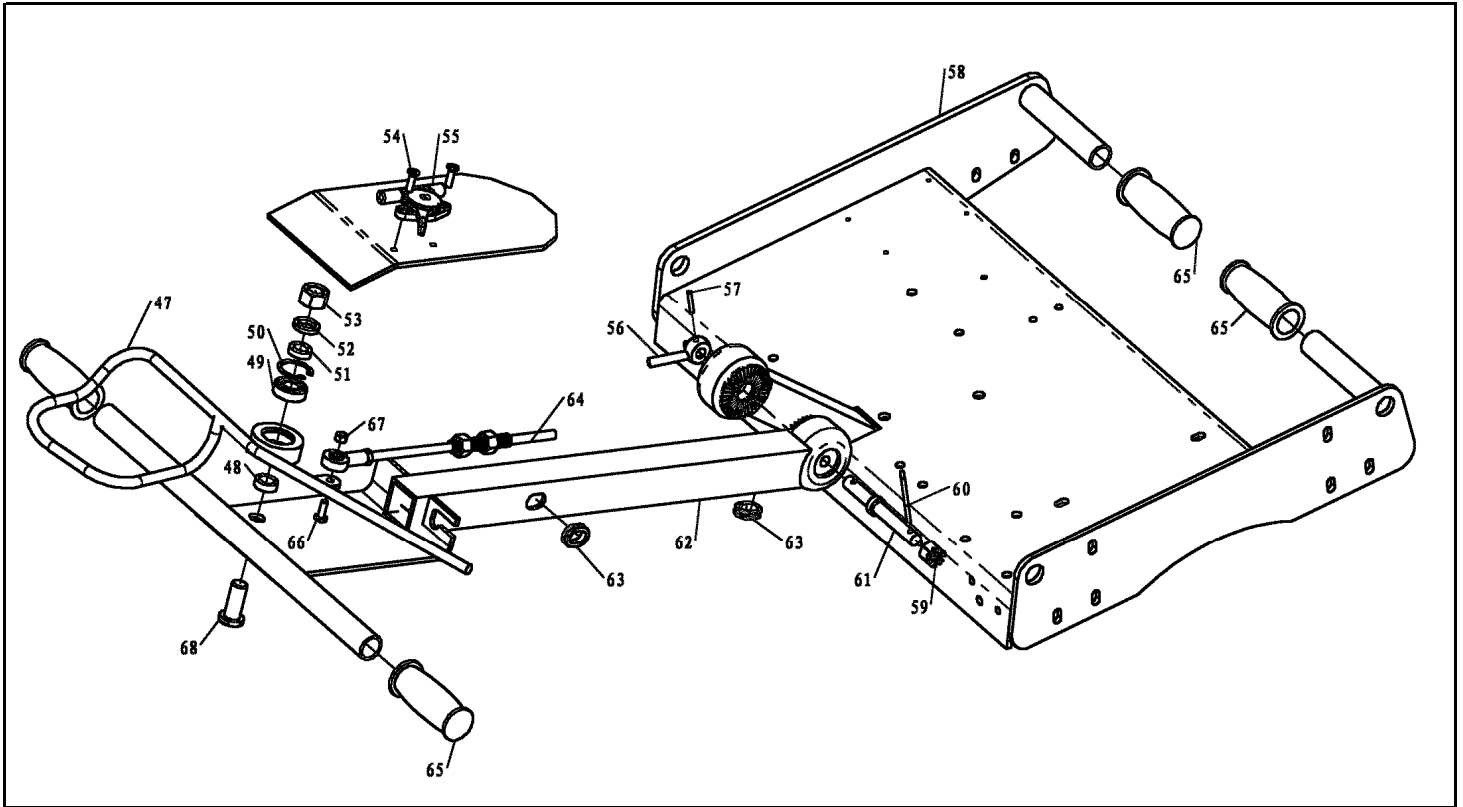

ITEM NO	PART NO.	DESCRIPTION	QTY	REMARK
47	MYZSK180.00.03-01	OPERATION LEVER	1	
48	MYZSK180.00.03-05	GASKET	1	
49	MYZSK180.ZC-5	BEARING	1	
50	GB493.1-Φ32	RETAINING RING Φ32	1	
51	MYZSK180.00.03-06	GASKET	1	
52	GB93-16	SPRING WASHER 16	1	
53	GB889-M16	NUT M16	1	
54	GB819.1-M6X20	SCREW M6X20	2	
55	YK1D-060DF1490H035	THROTTLE CONTROL ASSY	1	
56	JB270.8-M12X80	LEVER	1	
57	GB879-Φ4X25	PIN	1	
58	MYZSK180.00.01	BASE PLATE	1	
59	GB6180-M12	NUT M12	1	
60	GB91-4X50	PIN	1	
61	MYZSK180.00.03-07	BOLT	1	
62	MYZSK180.00.03-02.4	HANDLE	1	
63	MYZSK180.00.03.08	PROTECTION SLEEVE	2	
64	080BB1010H040	SHAFT	1	
65	MG12-0731	RUBBER COVER, HANDLE	4	
66	MYZSK180.00.03-3	PIN	1	
67	GB889-M6	NUT M6	1	
68	MYZSK180.00.03-04	SHAFT	1	

# MSR58 PARTS LIST C — DRUM CPL

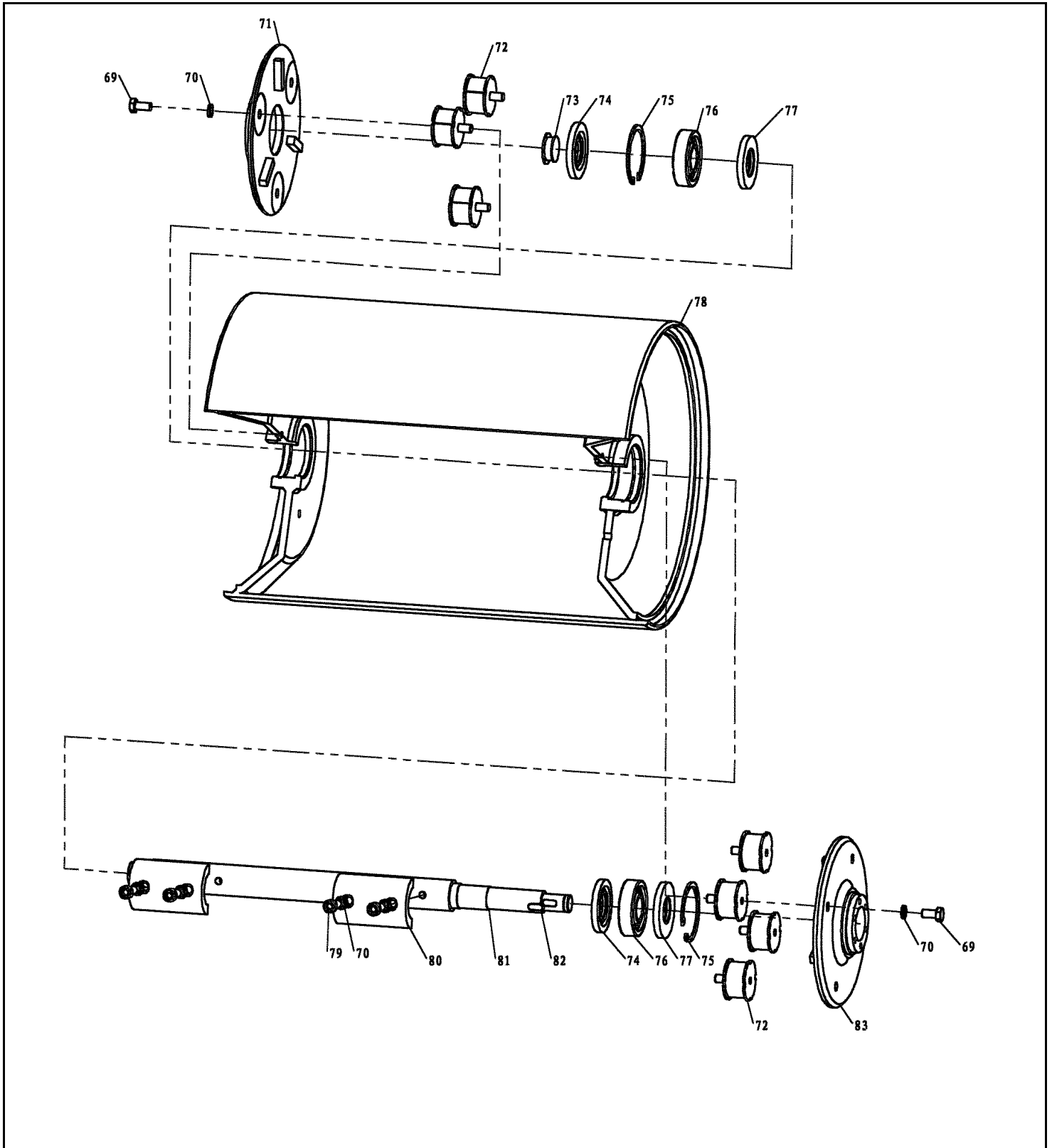

## MSR58 PARTS LIST C — DRUM CPL

ITEM NO.	PART NO.	DESCRIPTION	QTY	REMARK
69	GB5780-M10X20	BOLT M10X20	7	
70	GB93-10	SPRING WASHER 10	11	
71	MYZSK180.00.02.02	MOUNTING SOCKET,LEFT	1	
72	MYD170.02.06	VIBRATION DAMPER	7	
73	MYD170.00.02.03	END SOCKET	1	
74	GB13871-72X30X8	SEAL WASHER	2	
75	GB493.1-Φ72	RETAINING RING Φ72	2	
76	MYZSK180.ZC-3	BEARING	2	
77	MYD170.MFQ-1	SEAL WASHER	2	
78	MYZSK180.00.02.01	DRUM	1	
79	GB70.1-M10X30	SOCKET HEAD SCREW M10X30	4	
80	MYZSK180.00.02.04	UNBALANCE WEIGHT	2	
81	MYZSK180.00.02.05	SHAFT	1	
82	GB1096-M8X20	KEY 8X20	1	
83	MYZSK180.00.02.07	MOUNTING SOCKET,RIGHT	1	

# MSR58 PARTS LIST D — LOWER FRAME

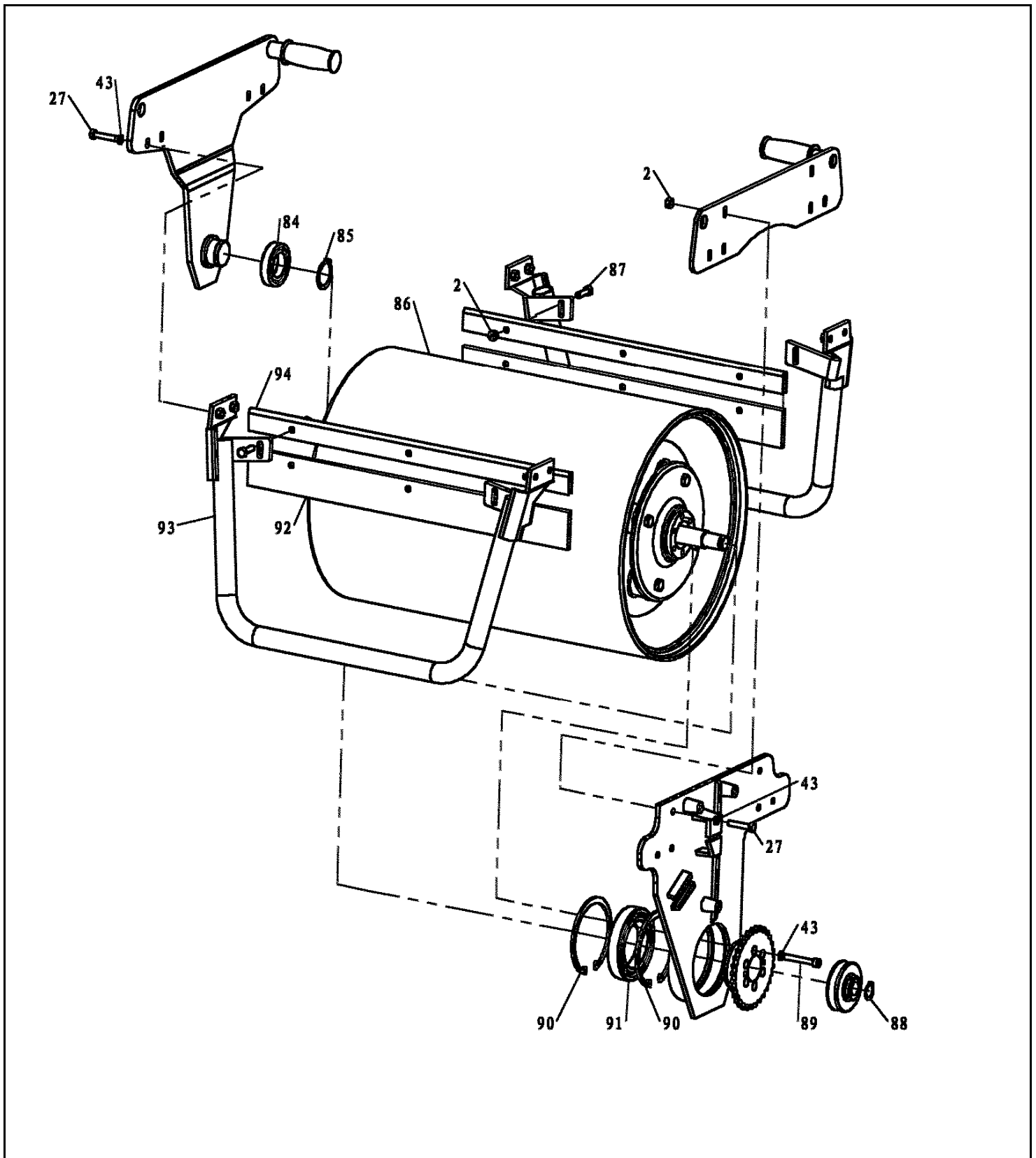



## MSR58 PARTS LIST D — LOWER FRAME

ITEM NO.	PART NO.	DESCRIPTION	QTY	REAMRK
27	GB5780-M8X40	BOLT M8X40	12	
43	GB93-8	SPRING WASHER 8	12	
84	MYZSK180.ZC-2	BEARING	1	
85	GB894.1-Φ40	RETAINING RING Φ40	1	
86	MYZSK180.00.02	DRUM CPL	1	
2	GB889-M8	NUT M8	6	
87	GB5780-M8X30	BOLT M8X30	4	
88	GB894.1-Φ22	RETAINING RING Φ22	1	
89	GB70.1-M8X50	SOCKET HEAD SCREW M8X50	6	
90	GB493.1-Φ115	RETAINING RING Φ115	2	
91	MYZSK180.ZC-1	BEARING	1	
92	MYZSK180.00.01.13	SCRAPER	2	
93	MYZSK180.00.01.11	FRAME	2	
94	MYZSK180.00.01.12	FIXED PLATE, SCRAPER	2	

## MSR58 PARTS LIST E — PROTECTIVE COVER

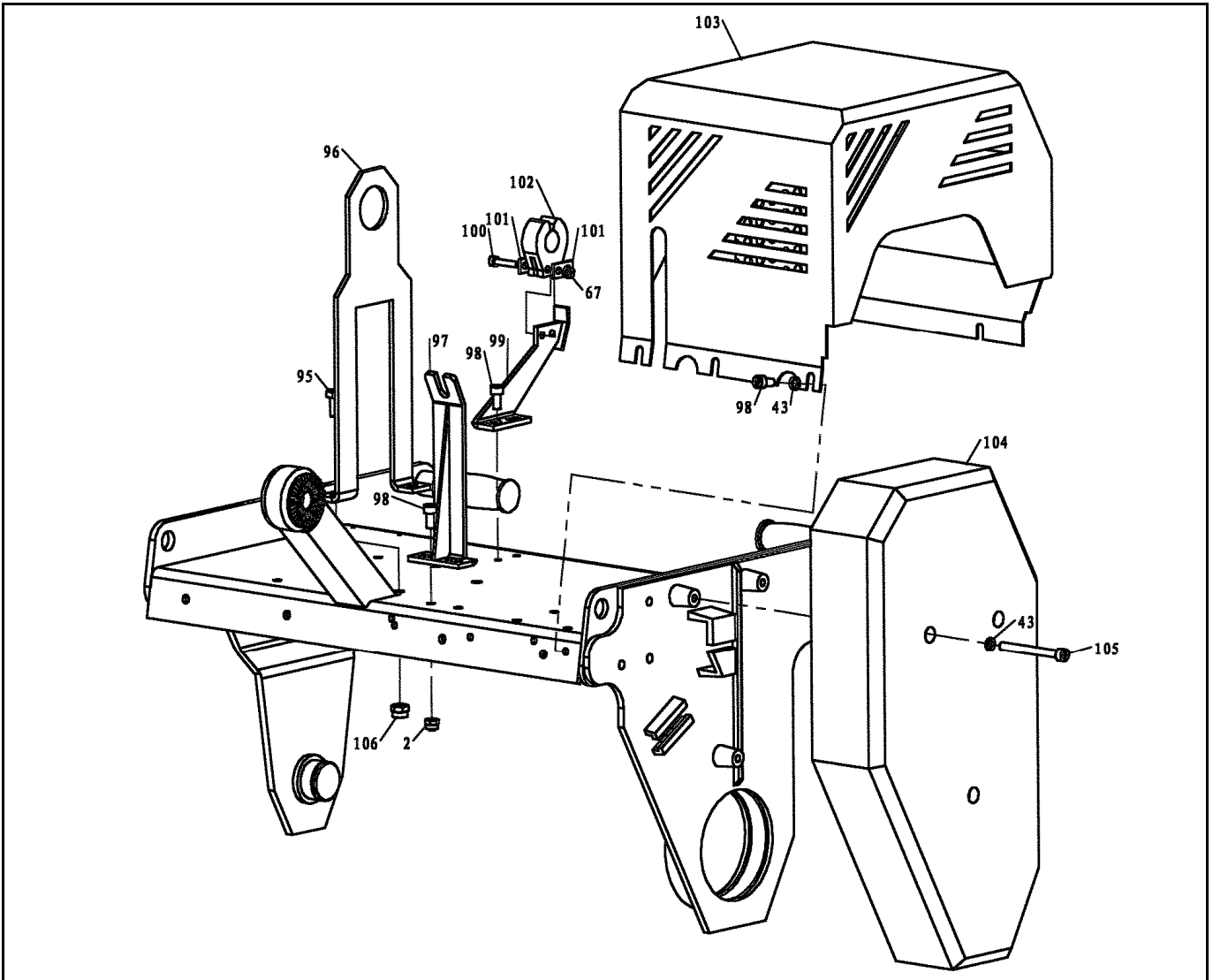

ITEM NO.	PART NO.	DESCRIPTION	QTY	REMARK
95	GB5783- M10X20	BOLT M10X20	2	
96	MYZSK180.00.01.06	LIFTING POINT	1	
97	MYZSK180.00.01.07	BRACKET	1	
98	GB70.1-M8X16	SOCKET HEAD SCREW M8X16	9	
99	MYZSK180.00.01.30	BRACKET	1	
100	GB70.1-M6X30	SOCKET HEAD SCREW M6X30	2	
101	MH4012.00.18	CONNECTION STRAP	2	
102	MH4012.00.17	FIXED BLOCK	1	
67	GB889-M6	LOCK NUT M6	2	
103	MYZSK180.00.01.14	UPPER PROTECTIVE COVER	1	
104	MYZSK180.00.02.11	SIDE PROTECTIVE COVER	1	
43	GB93-8	SPRING WASHER 8	8	
105	GB70.1-M8X80	SOCKET HEAD SCREW M8X80	3	
2	GB889-M8	LOCK NUT M8	2	
106	GB889-M10	LOCK NUT M10	2	

## MSR58 PARTS LIST F — WATER TANK ASSY

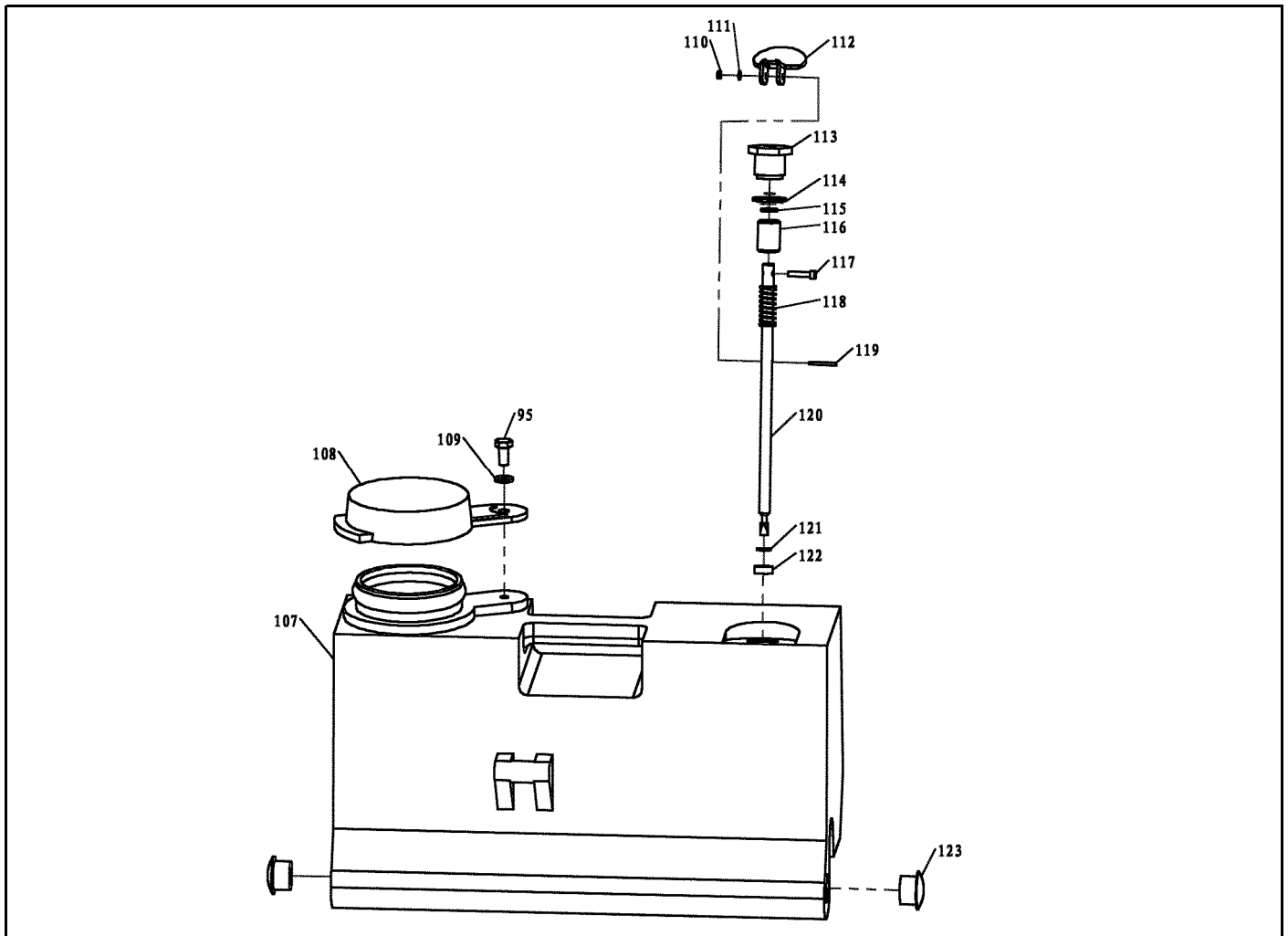

ITEM NO.	PART NO.	DESCRIPTION	QTY	REMARK
107	MYZSK180.00.04.01	WATER TANK	1	
108	MH4012.00.30	WATER TANK CAP	1	
109	GB97.1-10	WASHER 10	1	
95	GB5783- M10X20	BOLT M10X20	1	
110	GB889-M4	NUT M4	1	
111	GB97.1-4	FLAT WASHER 4	1	
112	MYZSK180.00.04.02	COCK	1	
113	MYZSK180.00.04.05	END SOCKET	1	
114	MYZSK180.OXQ-1	O-RING	1	
115	MYZSK180.OXQ-2	O-RING	1	
116	MYZSK180.00.04.07	SLEEVE	1	
117	GB70.1-M5X25	SOCKET HEAD SCREW M5X25	1	
118	MYZSK180.00.04.08	SPRING	1	
119	GB879-3X30	PIN	1	
120	MYZSK180.00.04.04	SHAFT	1	
121	MYZSK180.00.04.12	WASHER	1	
122	MYZSK180.00.04.09	SEAL GASKET	1	
123	MYZSK180.00.04.10	PLUG	2	

## MSR58 PARTS LIST G — CHAIN TENSION CPL

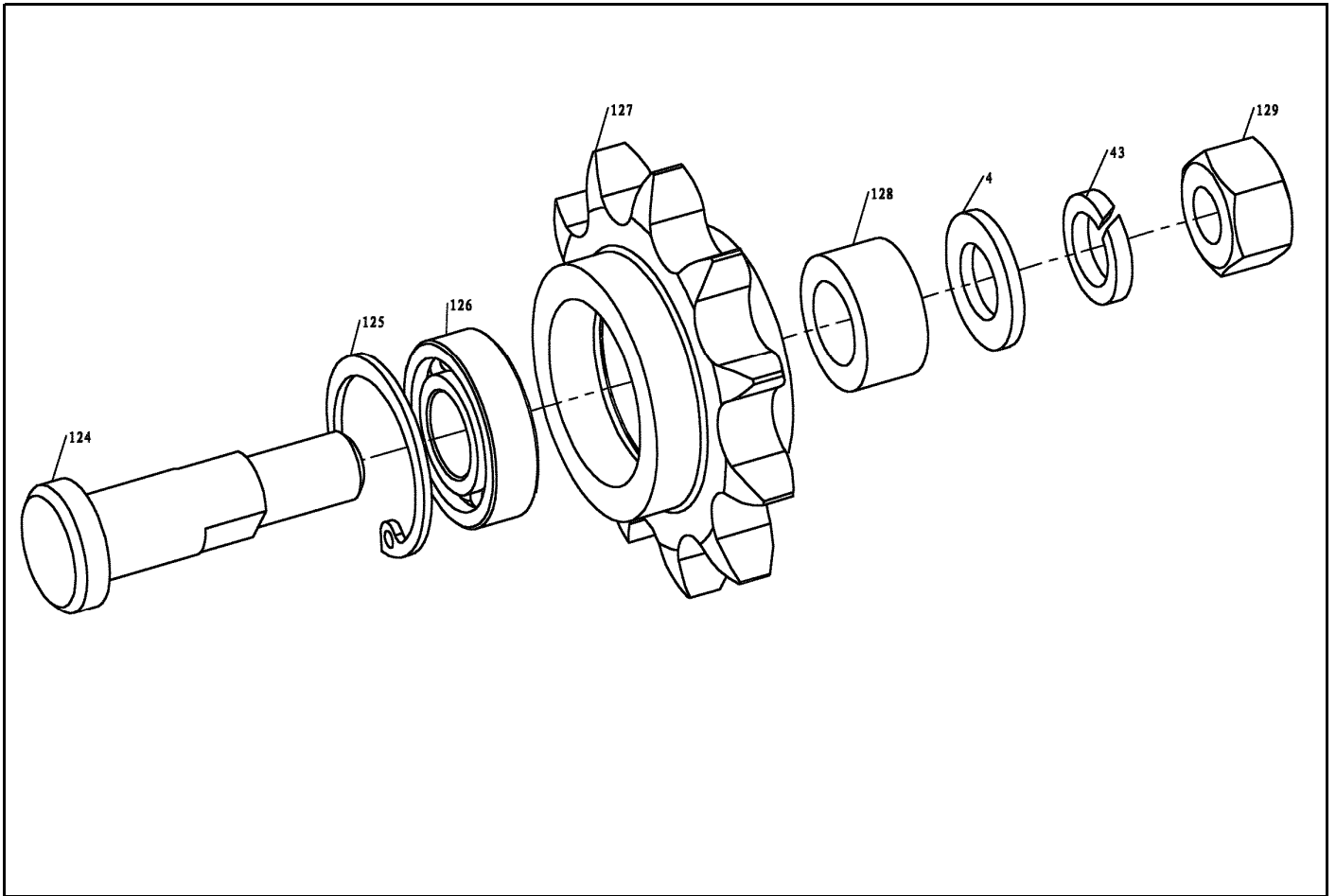

ITEM NO.	PART NO.	DESCRIPTION	QTY	REMARK
124	MYZSK180.00.01.20-3	SHAFT	1	
125	GB893.1-Φ22	RETAINING RING 22	1	
126	GB276-61900-2Z	BEARING	1	
127	MYZSK180.00.01.20-1	CHAIN TENSION WHEEL	1	
128	MYZSK180.00.01.20-2	PRESSURE PAD	1	
4	GB97.1-8	FLAT WAHSER 8	1	
43	GB93-8	SPRING WASHER 8	1	
129	GB41-M8	NUT M8	1	

# MSR58 PARTS LIST H — BELT TENSION CPL

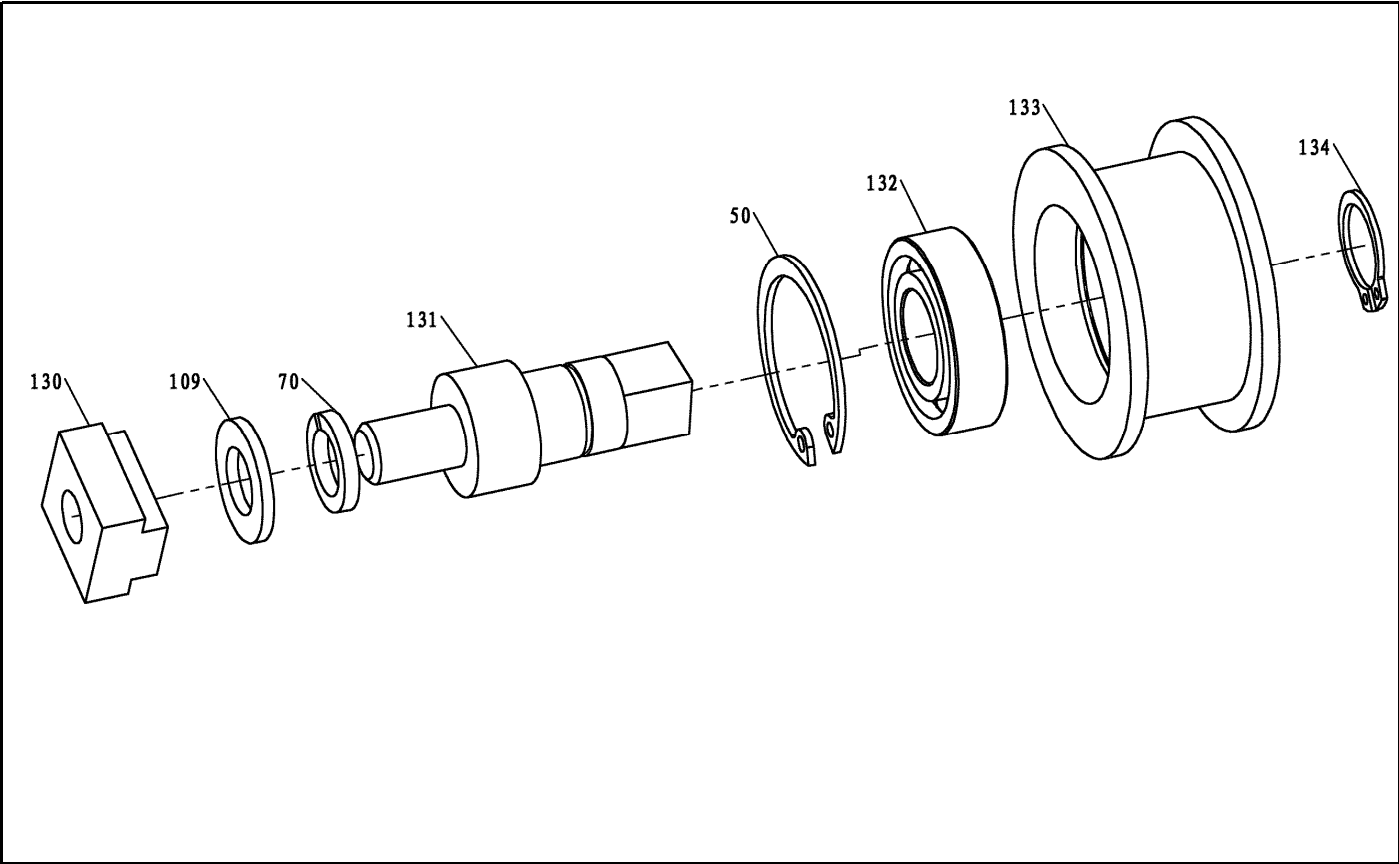

ITEM NO.	PART NO.	DESCRIPTION	QTY	REMARK
130	MYZSK180.00.01.18-2	T NUT	1	
109	GB97.1-10	FLAT WASHER 10	1	
70	GB93-10	SPRING WASHER 10	1	
131	MYZSK180.00.01.18-3	SHAFT	1	
50	GB893.1-Φ32	RETAINING RING 32	1	
132	GB276-6002-2RZ	BEARING	1	
133	MYZSK180.00.01.18-1	BELT TENSION WHEEL	1	
134	GB894.1-Φ15	RETAINING RING 15	1	



*Distributed By*



**MASALTA ENGINEERING CO., LTD**

Add: Weisi Road, Baohe Industrial Estate, Hefei, China  
Tel: 86-551-4846600, 4846601 Fax: 86-551-4846616  
E-mail: [sales@masalta.com.cn](mailto:sales@masalta.com.cn), [masalta@mail.hf.ah.cn](mailto:masalta@mail.hf.ah.cn),  
[Http://www.masalta.com.cn](http://www.masalta.com.cn)

## **ОФИЦИАЛЬНЫЙ ДИЛЕР В УКРАИНЕ:**

[storgom.ua](http://storgom.ua)

## **ГРАФИК РАБОТЫ:**

Пн. – Пт.: с 8:30 по 18:30

Сб.: с 09:00 по 16:00

Вс.: с 10:00 по 16:00

## **КОНТАКТЫ:**

+38 (044) 360-46-77

+38 (066) 77-395-77

+38 (097) 77-236-77

+38 (093) 360-46-77

Детальное описание товара: <https://storgom.ua/product/vibrokatokmasaltamsr58h.html>

Другие товары: <https://storgom.ua/vibracionnyekatki.html>