

CLASS

TILE BRIDGE SAWS

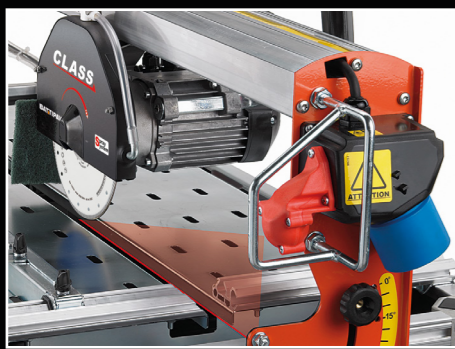

CONTROL BOARD

The control board includes:

- Switch with release coil.
- Overheat protection with manual reset in the event of the disk jamming.
- Red light for net connection.
- Green light for machine on function.
- Laser instrument for the maximum cutting precision.



EXTENSION SIDE BENCH

It is very practical when need to cut large size of tiles and marble slabs.

OPTIONAL



STORAGE

Built to reduce at the minimum the encumbrance during the carriage and above all the storage space.



Designed and made in Italy



	Art. 65671	Art. 65670	Art. 65901	Art. 65900	Art. 651101	Art. 651100
DIAMOND DISK (special gres included)	ø200 mm (int ø25,4 mm)					
ENGINE	230V 50Hz 1000W					
ROTATION SPEED	2800 rpm					
MAX CUTTING LENGTH	670 mm		900 mm		1100 mm	
MAX CUTTING DEPTH	40 mm					
MAX CUTTING DEPTH AT 45°	40 mm					
MAX CUTTING DEPTH WITH TWO RUNS	55 mm					
MAX SIZE TILE FOR DIAGONAL CUT	470 x 470 mm		635 x 635 mm		775 x 775 mm	
WORKING TABLE SIZE	523 x 652 mm		523 x 882 mm		1084 x 523 mm	
WATER PUMP TYPE	S0 Type					
KIT WHEELS	Standard	Optional	Standard	Optional	Standard	Optional
LASER INSTRUMENT	Standard	-	Standard	-	Standard	-
DIMENSION MACHINE IN SERVICE	675x1010x h. 1180 mm		675x1240x h. 1180 mm		675x1505x h. 1275mm	
DIMENSION MACHINE IN STOCK	720x1100x h. 940 mm		720x1300x h. 940 mm		720x1440x h. 940 mm	
NET WEIGHT	40 Kg	37 Kg	44 Kg	41 Kg	48 Kg	45 Kg

BATTIPAVTM
MACCHINE PER EDILIZIA | MACHINES FOR BUILDING

Z. i. 2 - Via Cavatorta, 6/1 | 48033 Cotignola (Ra) | ITALY
Tel. +39 0545 40004 | Fax +39 0545 41724
www.battipav.com | sales@battipav.com

AUTHORIZED DEALER:

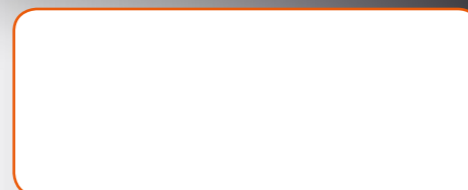

October 2016

APPLICATION

Built to cut stoneware, porcelain, tiles and marble.

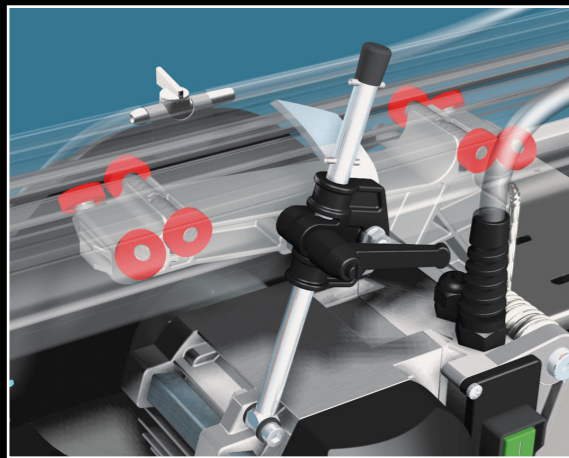

The carriage engine group slides with 8 ball-bearings on interchangeable stainless steel track. So doing the sliding is very fast and precise.



TILE SUPPORT
Very precise tile support with millimetric scale of quick reading.



Position 45° angle cuts.



The cutting head is horizontally pivoted and can be locked at the intended height. It makes every kind of shape.



ORIGINAL RECYCLING PUMP

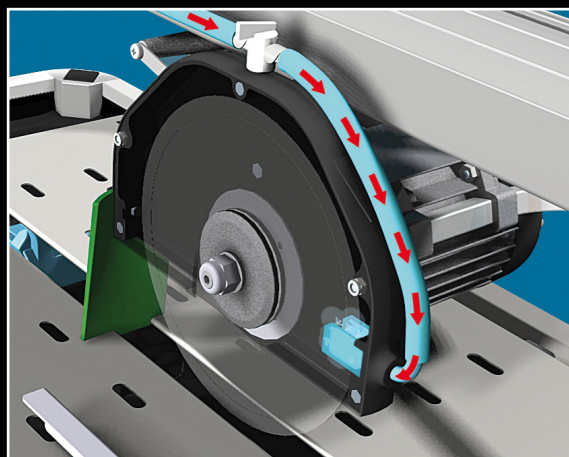

ОФИЦИАЛЬНЫЙ ДИЛЕР В УКРАИНЕ:

storgom.ua

ГРАФИК РАБОТЫ:

Пн. – Пт.: с 8:30 по 18:30

Сб.: с 09:00 по 16:00

Вс.: с 10:00 по 16:00

КОНТАКТЫ:

+38 (044) 360-46-77

+38 (066) 77-395-77

+38 (097) 77-236-77

+38 (093) 360-46-77

Детальное описание товара: <https://storgom.ua/product/elektricheskii-plitkorez-battipav-class-9-0.html>

Другие товары: <https://storgom.ua/elektricheskie-plitkorezy.html>