

FEKA BVP

SUBMERSIBLE PUMPS



TECHNICAL DATA

Operating range:

from 1 to 18 m³/h with head up to 12 metres.

Liquid temperature range:

from 0 °C to +35 °C.

Pumped liquid:

dirty water with maximum solid particle size 38 mm.

Max. immersion depth: 7 metres.

APPLICATIONS

Powerful submersible pumps for draining and emptying applications. Suitable for pumping dirty water with solid particle size up to 38 mm. Automatic version with float switch for automatic pump start and stop also available

CONSTRUCTION FEATURES OF THE PUMP

Hydro resistant technopolymer pump body, wear-free impellers, cover, and suction grid.
Corrosion and oxidation resistant materials.

CONSTRUCTION FEATURES OF THE MOTOR

Submersible type continuous duty asynchronous motor.
Thermal overheating protection.
Wear-resistant motor shaft.

MATERIALS

N.	PARTS*	MATERIALS
1	CAP	TECHNOPOLYMER
2	FLOAT	TECHNOPOLYMER
3	IMPELLER	TECHNOPOLYMER
4	NUT	A2 DIN982-UNI7473 STAINLESS STEEL
5	V. RING	NBR
6	WASHER	A2 STAINLESS STEEL
7	OR RING	NBR
8	MOTOR RING	TECHNOPOLYMER
9	MOTOR	CASE ALUMINIUM
		ROTOR SHAFT AISI 416 STAINLESS STEEL UNI EN 10088-1 X12CRS13
10	OR RING	NBR
11	BODY	TECHNOPOLYMER

* In contact with the liquid

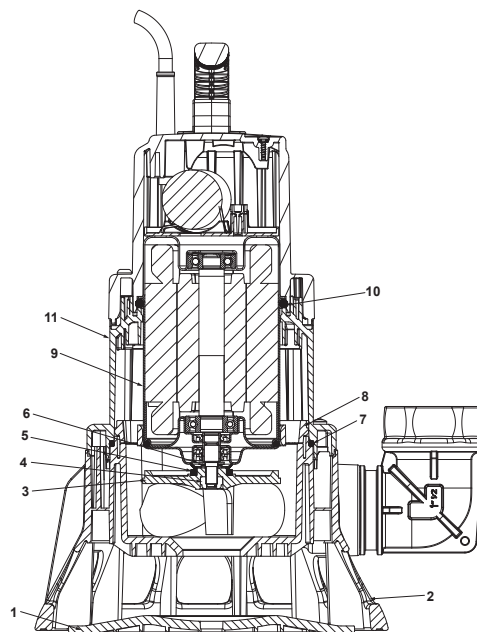

FEKA RANGE

SUBMERSIBLE PUMPS

PERFORMANCE RANGE

The performance curves are based on kinematic viscosity values = 1 mm²/s and density equal to 1000 kg/m³. Curve tolerance according to ISO 9906.

GRAPHIC SELECTION TABLE

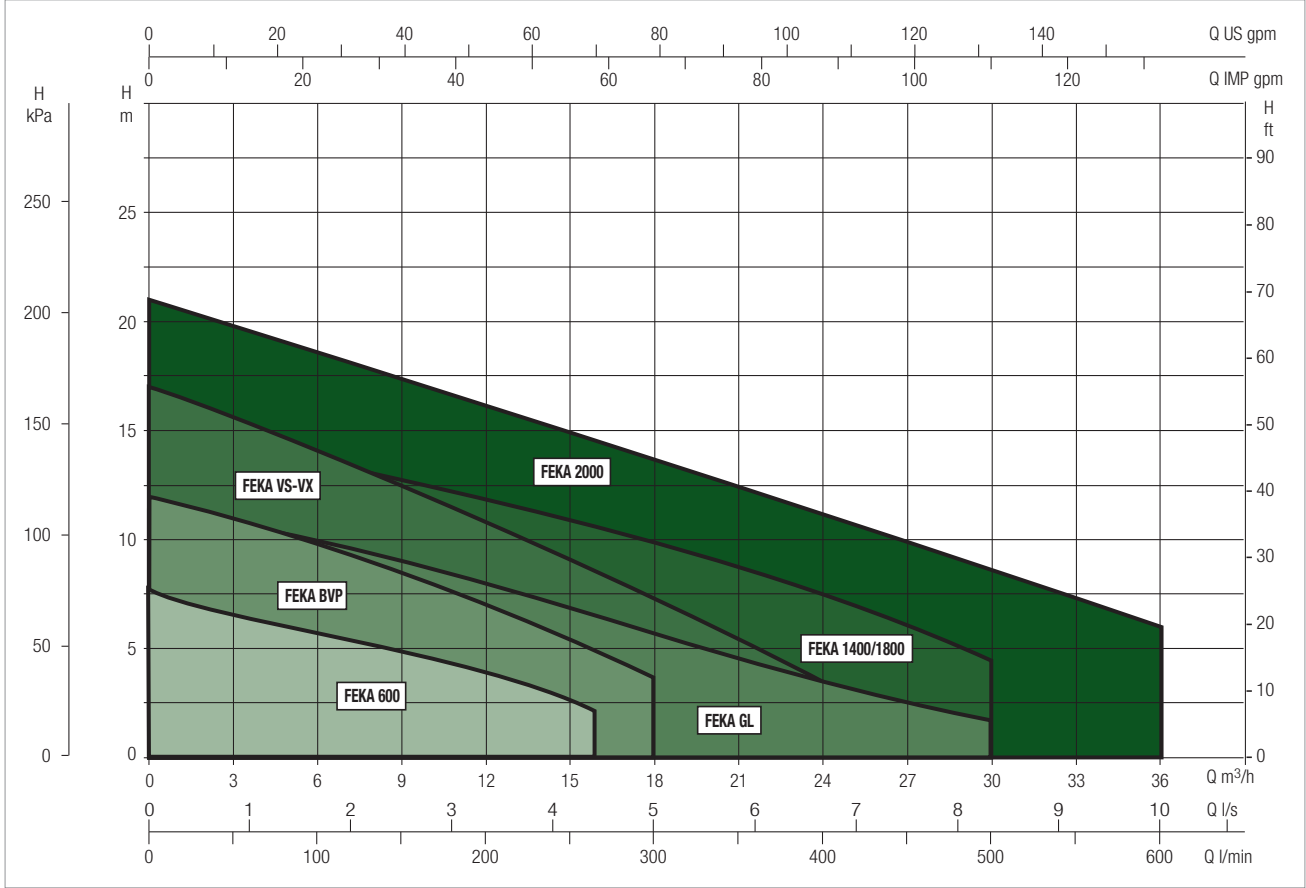

SELECTION TABLE - FEKA BVP

MODEL	Q= m ³ /h	0	3	6	9	12	15	18	24	30	36
	Q=l/min	0	50	100	150	200	250	300	400	500	600
FEKA BVP 700 M	H (M)	10.5	9.5	8.1	7	5.1	4	1.5			
FEKA BVP 750 M	H (M)	12	11	9.8	8.8	7	6	3.6			

FEKA BVP - SEWAGE WATER DRAINING SUBMERSIBLE PUMPS FOR DOMESTIC USE

Liquid temperature range: from 0 °C to +35 °C

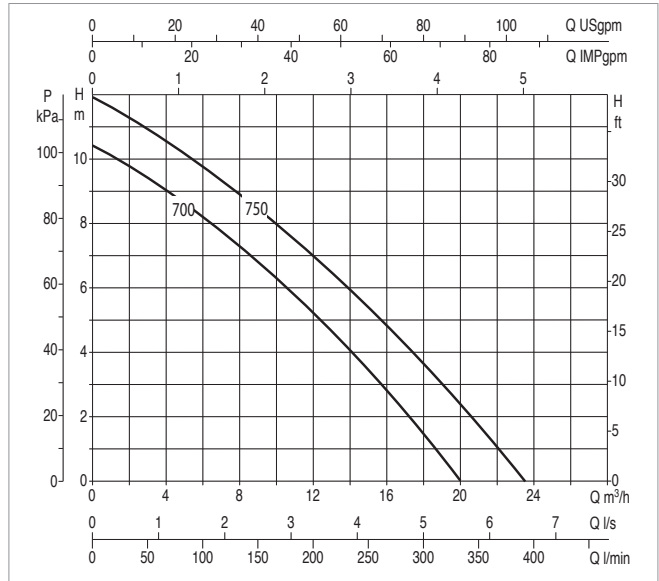
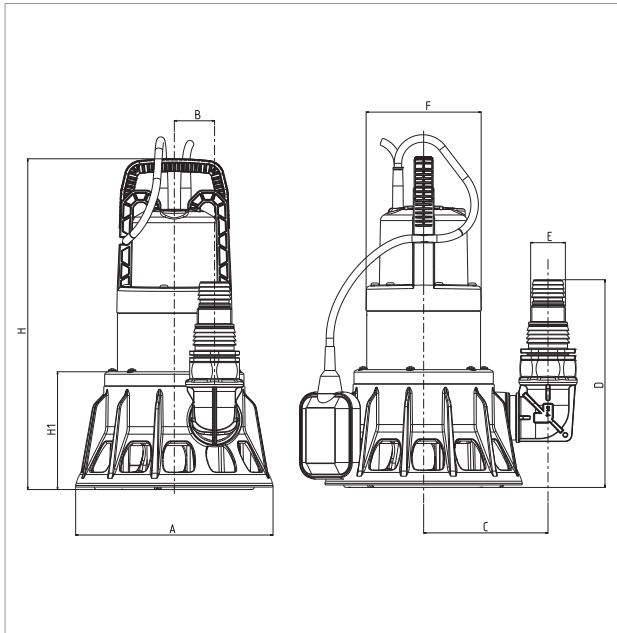

The performance curves are based on kinematic viscosity values = 1 mm²/s and density equal to 1000 kg/m³. Curve tolerance according to ISO 9906.

MODEL	ELECTRICAL DATA				
	POWER INPUT 50 Hz	P1 MAX kW	P2 NOMINAL		In A
			kW	HP	
FEKA BVP 700 M-A	1 x 230V ~	1.0	0.70	0.95	4.6
FEKA BVP 750 M-A	1 x 230V ~	1.1	0.75	1	5.6

MODEL	A	B	C	D	E	F	H	H1	DNM GAS	PACKING DIMENSIONS			CABLE	VOLUME (m ³)	WEIGHT kg
										L/A	L/B	H			
FEKA BVP 700 M-A	240	49	150	250	M40	140	400	142	1" 1/2	244	244	442	10 mt.	0.026	27
FEKA BVP 750 M-A	240	49	150	250	M40	140	400	142	1" 1/2	244	244	442	10 mt.	0.026	27

ОФИЦИАЛЬНЫЙ ДИЛЕР В УКРАИНЕ:

storgom.ua

ГРАФИК РАБОТЫ:

Пн. – Пт.: с 8:30 по 18:30

Сб.: с 09:00 по 16:00

Вс.: с 10:00 по 16:00

КОНТАКТЫ:

+38 (044) 360-46-77

+38 (066) 77-395-77

+38 (097) 77-236-77

+38 (093) 360-46-77

Детальное описание товара:

<https://storgom.ua/product/fekalnyj-nasos-dab-feka-bvp-7-0-m-a-601226-1.html>

Другие товары: <https://storgom.ua/fekalnyye-nasosy.html>