

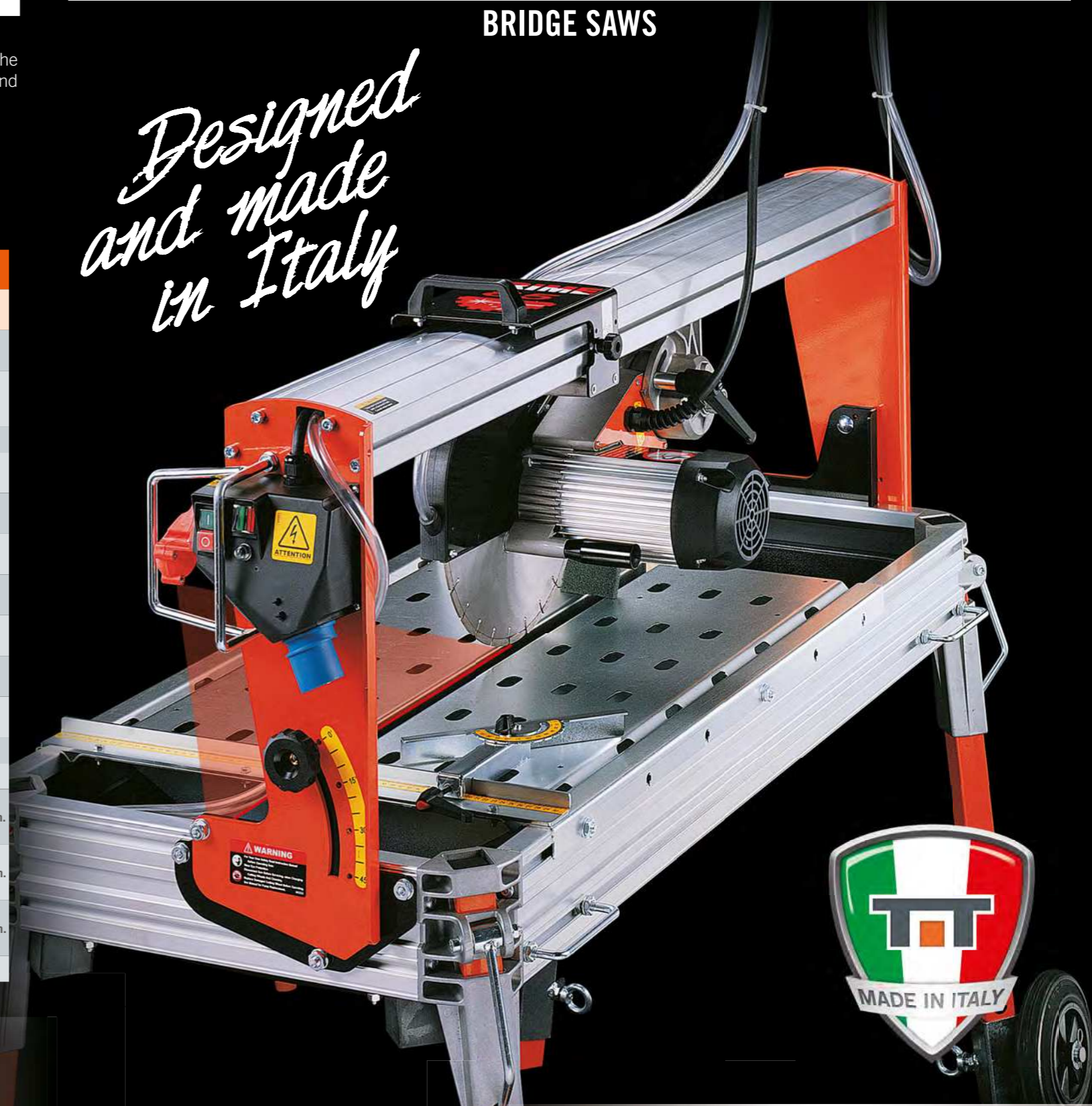

# PRIME

## BRIDGE SAWS

*Designed and made in Italy*



### CONTROL BOARD

The control board includes:

- Switch with release coil.
- Overheat protection with manual reset in the event of the disk jamming.
- Red light for net connection.
- Green light for machine on function.
- Laser instrument for the maximum cutting precision.

### KIT WHEELS

The wheels can be fixed to the legs by means of eyebolts.

The machine can be easily moved if lightly lifted up by the handles.

### STORAGE

Build to reduce at the maximum the encumbrance during the carriage and above all the storage space.

	PRIME 55		PRIME 85		PRIME 100		PRIME 120		PRIME 150		PRIME 200	
Article	Art. 9055	Art. 90551	Art. 9085	Art. 90851	Art. 9100	Art. 91001	Art. 9120	Art. 91201	Art. 9150	Art. 91501	Art. 9200	Art. 92001
CUTTING DISK Ø350 (int ø25,4mm.)	Optional		Optional		Optional		Optional		Optional		Optional	
ENGINE	Single phase 115V   50Hz 3Hp/2,2Kw		Single phase 115V   50Hz 3Hp/2,2Kw		Single phase 115V   50Hz 3Hp/2,2Kw		Single phase 115V   50Hz 3Hp/2,2Kw		Single phase 115V   50Hz 3Hp/2,2Kw		Single phase 115V   50Hz 3Hp/2,2Kw	
ROTATION SPEED	2800 rpm.		2800 rpm.		2800 rpm.		2800 rpm.		2800 rpm.		2800 rpm.	
AMPEROMETRICAL PROTECTION	13 A		13 A		13 A		13 A		13 A		13 A	
MAX CUTTING LENGTH	550 mm.		850 mm.		1000 mm.		1200 mm.		1500 mm.		2000 mm.	
MAX CUTTING DEPTH AT 90°	110 mm.		110 mm.		110 mm.		110 mm.		110 mm.		110 mm.	
MAX CUTTING DEPTH WITH 2 RUNS	180 mm.		180 mm.		180 mm.		180 mm.		180 mm.		180 mm.	
MAX CUTTING DEPTH AT 45°	80 mm.		80 mm.		80 mm.		80 mm.		80 mm.		80 mm.	
WORKING TABLE SIZE	550 x 620 mm.		850 x 620 mm.		850 x 620 mm.		1200 x 620 mm.		1500 x 620 mm.		2050 x 625 mm.	
WATER RECYCLING PUMP TYPE	S3 standard		S3 standard		S3 standard		S3 standard		S3 standard		S3 standard	
KIT WHEELS	Optional	Standard	Optional	Standard	Optional	Standard	Optional	Standard	Optional	Standard	Optional	Standard
LASER INSTRUMENT	Optional	Standard	Optional	Standard	Optional	Standard	Optional	Standard	Optional	Standard	Optional	Standard
DIMENSION MACHINE IN SERVICE	770x1280x h. 1350 mm.		770x1580x h. 1350 mm.		770x1730x h. 1350 mm.		770x1930x h. 1350 mm.		770x2230x h. 1350 mm.		770x2710x h. 1350 mm.	
DIMENSION MACHINE IN STOCK	720x1300x h. 1000 mm.		720x1600x h. 1000 mm.		720x1750x h. 1000 mm.		720x1950x h. 1000 mm.		720x2250x h. 1000 mm.		720x2750x h. 1000 mm.	
DIMENSION 3 MACHINES ON PALLET	720x1300x h. 2260 mm.		720x1600x h. 2260 mm.		720x1750x h. 2260 mm.		720x1950x h. 2260 mm.		720x2250x h. 2260 mm.		720x2750x h. 2260 mm.	
NET WEIGHT	75 Kg.		80 Kg.		83 Kg.		86 Kg.		92 Kg.		99 Kg.	

**BATTIPAV**

MACCHINE PER EDILIZIA | MACHINES FOR BUILDING

Z. i. 2 - Via Cavatorta, 6/1 | 48010 Cotignola (Ra) | ITALY  
 Tel. +39 0545 40004 | Fax +39 0545 41724  
 www.battipav.com | sales@battipav.com

AUTHORIZED DEALER:



March 2013

### APPLICATION

Built to cut bricks, natural-stones, concrete blocks, granite and marble slabs.

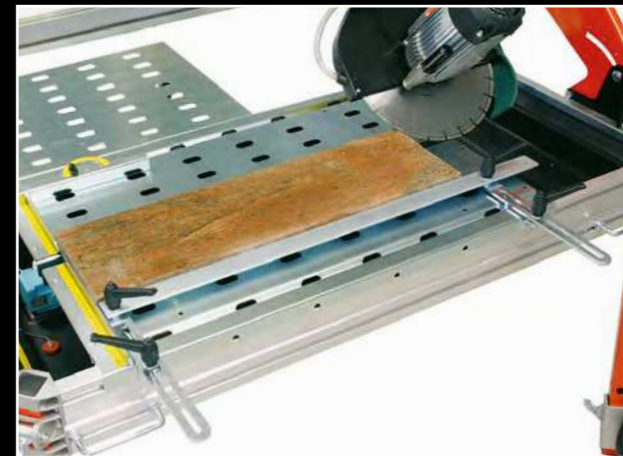
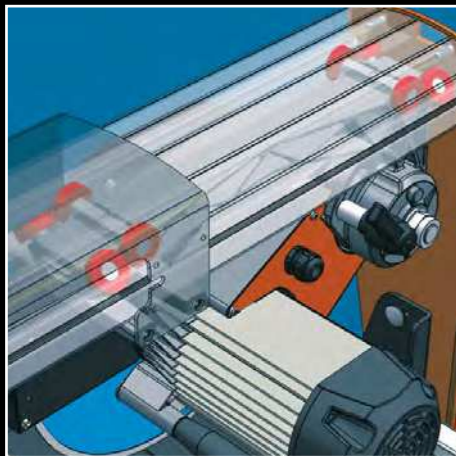

The carriage engine group slides with 8 ball-bearings on interchangeable stainless steel track. So doing the sliding is very fast and precise.

A graduated scale measures the adjustment of the cutting depth by means the locking of the tilting of the engine group.

The **CUTTING PROGRESS SYSTEM** with **HANDWHEEL** adjusts the movement of the cutting head forward or behind.

Position 45° angle cuts.

**SIDE BAR SUPPORT**  
Made to have the top precision during the execution of straight and angled cuts on slabs of large size. Adjustable angle-shot cut.  
Optional for the models: 85, 100, 120, 150 and 200

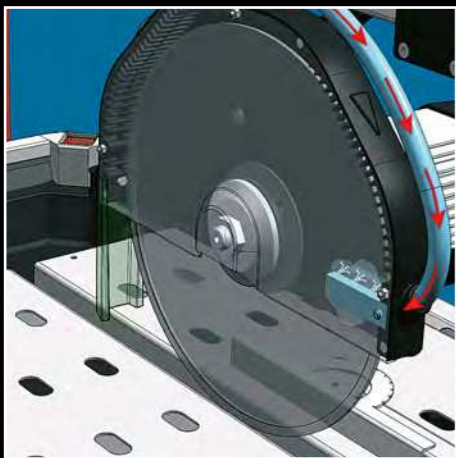

**Spray system**  
DISK'S LUBRICATION



ORIGINAL RECYCLING PUMP

**wdec**  
WATER DECANTING SYSTEM

**FastLEG**  
LEG FASTENING SYSTEM

**TT** **YouTube**  
OFFICIAL CHANNEL  
www.youtube.com/battipav

**ОФИЦИАЛЬНЫЙ ДИЛЕР В УКРАИНЕ:**

[storgom.ua](http://storgom.ua)

**ГРАФИК РАБОТЫ:**

Пн. – Пт.: с 8:30 по 18:30

Сб.: с 09:00 по 16:00

Вс.: с 10:00 по 16:00

**КОНТАКТЫ:**

+38 (044) 360-46-77

+38 (066) 77-395-77

+38 (097) 77-236-77

+38 (093) 360-46-77

Детальное описание товара: <https://storgom.ua/product/stanok-dlia-obrabotki-plitki-kamnia-nuova-battipav-prime-150s.html>

Другие товары: <https://storgom.ua/kamnerezy.html>