

# VITALS

КЕРІВНИЦТВО З ЕКСПЛУАТАЦІЇ

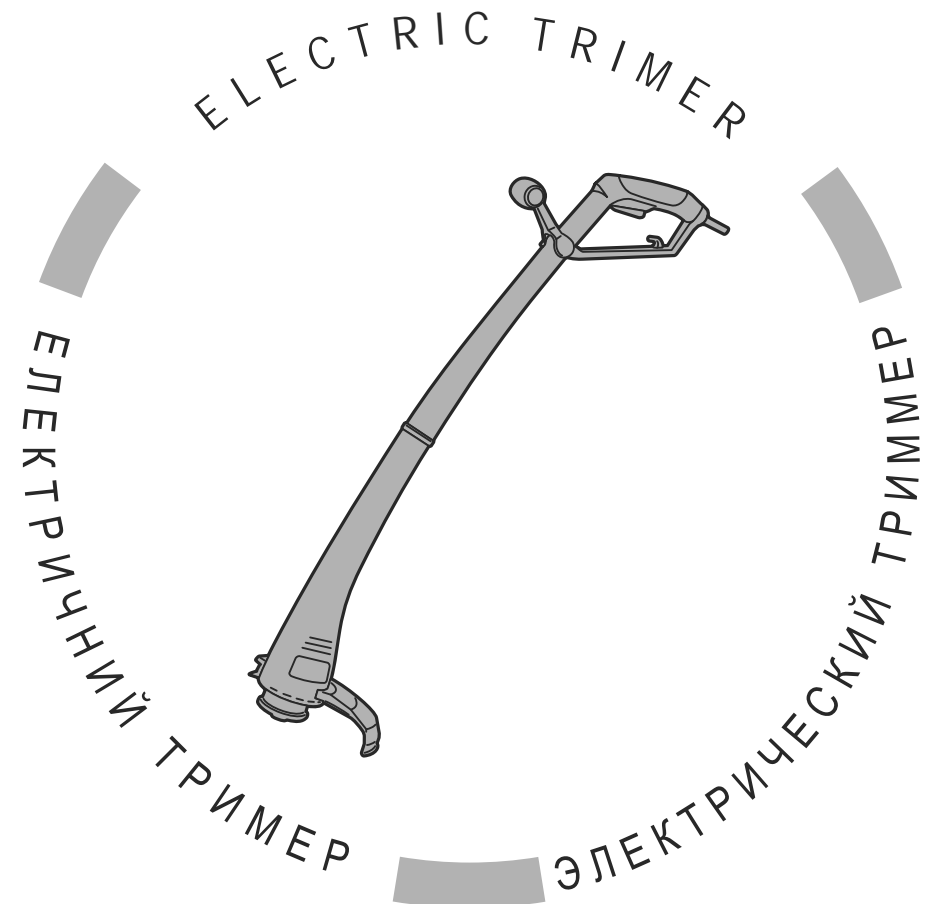

WWW.VITALS.COM.UA



MODEL

МОДЕЛ

МОДЕЛ

EZT 032m

ÓΕΔΑ-Ϊ ΝÜΕΑ

- 1.
- 2.
- 3.
- 4.
- 4.1.
- 4.2.
- 5.
- 5.1.
- 5.2.
- 6.
- 7.
- 8.
- 9.



- 6
- 8
- 9
- 10
- 10
- 10
- 15
- 15
- 20
- 23
- 27
- 29
- 31

!

«Vitals».

«Vitals»

«Vitals»

?

?

, 70, . 056-374-89-39.

Vitals Master EZT 032m

EN 786-2002;  
61029-1:2006;  
IEC 61000-3-2: 2004;  
CISPR 14-1: 2004;  
CISPR 14-2: 2007.



[Redacted text block]



[Redacted text block]



[Redacted text block]

. 056-374-89-39.

056-374-89-38,

www.vitals.com.ua.

«Vitals».

Vitals Master EZT 032m ( - )

1

Vitals Master EZT 032m

( , , )

: , :

Vitals Master EZT 032m:

0-120?

•  
•  
•

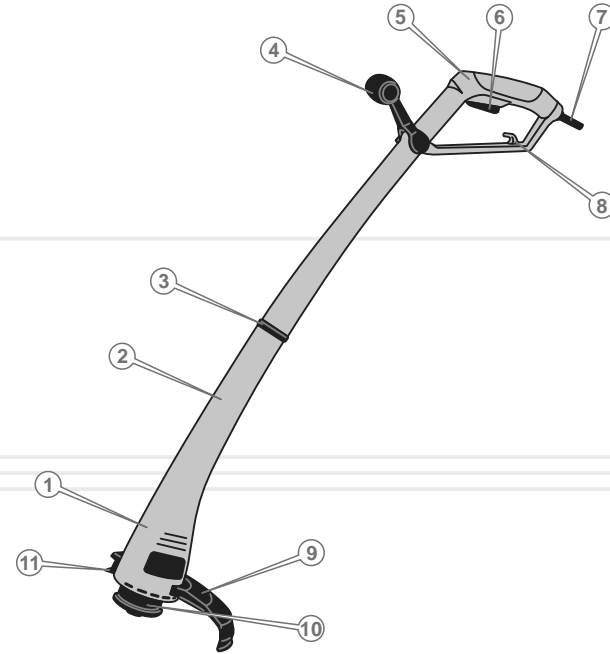

- 1.
- 2.
- 3.
- 4.
- 5.
- 6.
- 7.
- 8.
- 9.
- 10.
- 11.

2

3

УКРАЇНСЬКА

- 1.
- 2.
- 3.
- 4.
- 5.
- 6.

i

!

,

.

1

EZT 032m	
,	220
,	50
,	300
, /	12000
,	220
,	1,2
, / ?	2,45
,	545 160 140
/ ,	1,3 / 1,5

УКРАЇНСЬКА

8

9

4.1.



[Redacted text block]

4.2.

1.

2.

16

3.

4.

5.

6.

7.

8.

9.

10.

11.

12.

13.

14.

15.

16.

17.

18.

19.

20.

21.

22.

23.

24.

25.

26.

27.

28.

15

29.

30.

31.

32.

5.1.

1. (2) (2).
2. (2), (3, 4)
3. (5) (2).

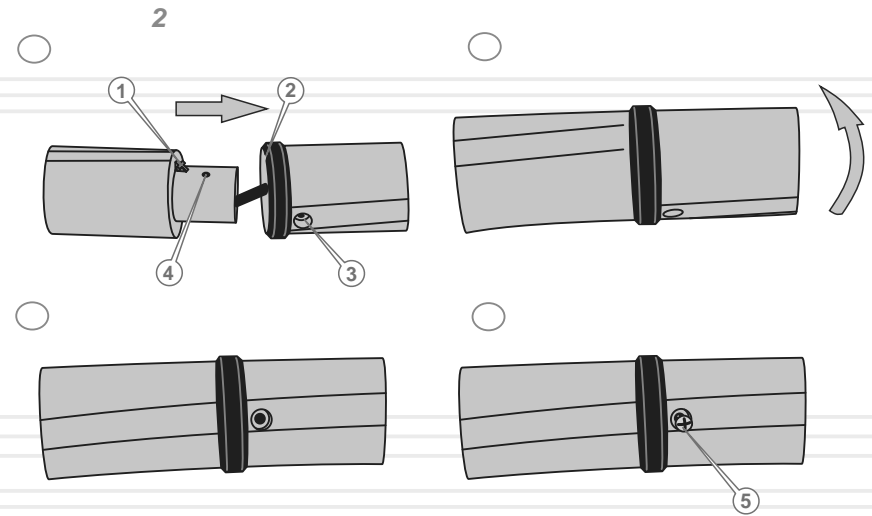



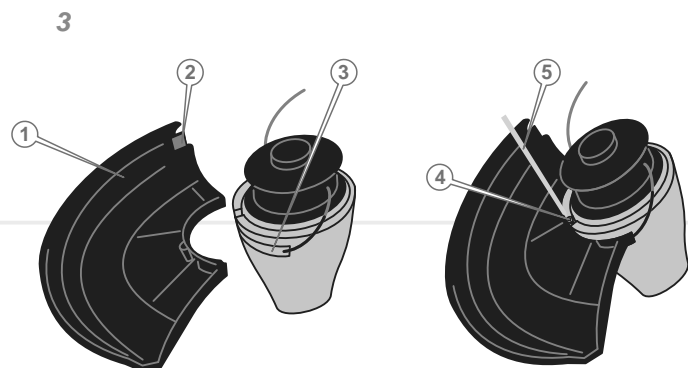

1. (1), (3).
2. (2), (4), (5).



! [Redacted text]



! [Redacted text]

( . 4)

0-120?

1. ' (1)
2. (2), (1), (2).

4

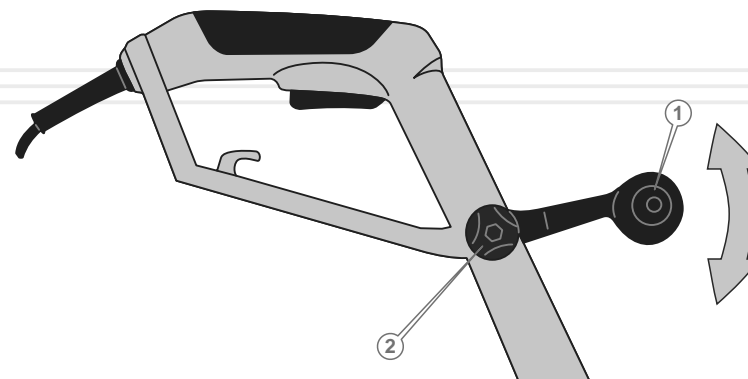

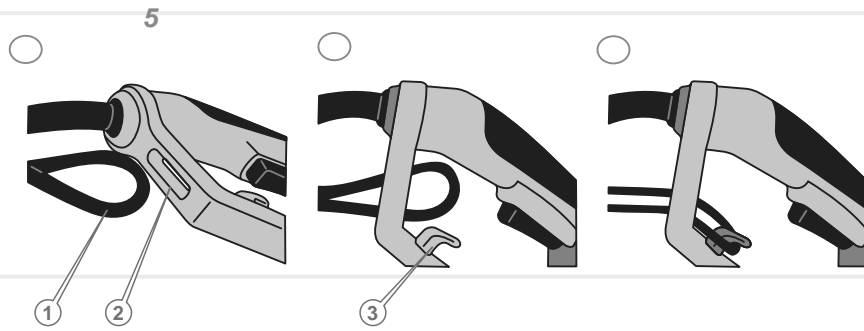

(2) (1) (6). (3)  
6, (15-17).

220 50 (2-4),

(3). 5. (1) (2)

6

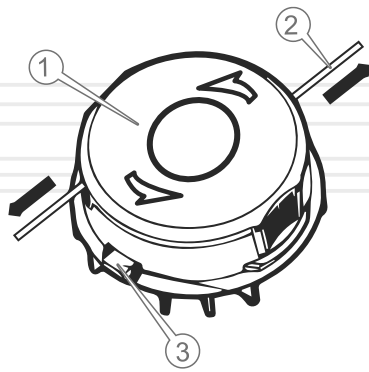

**!**

**!**

**!**

5.2.



[Redacted text block]



[Redacted text block]

7

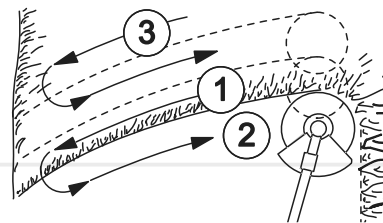

( 7).

( 3).

8

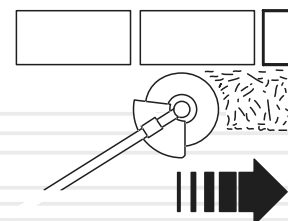

8,



[Redacted text block]

20

21

9

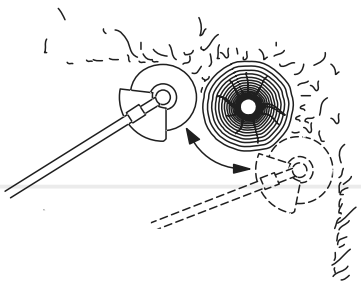

( 9).

6



!



!

2

	/		50
			3

		•	
		•	
		•	
		•	
		•	
		•	
		•	
		•	
		•	
		•	
		•	
		•	



!

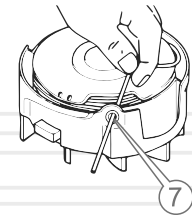
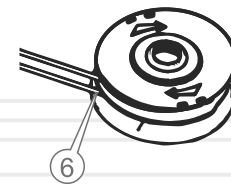
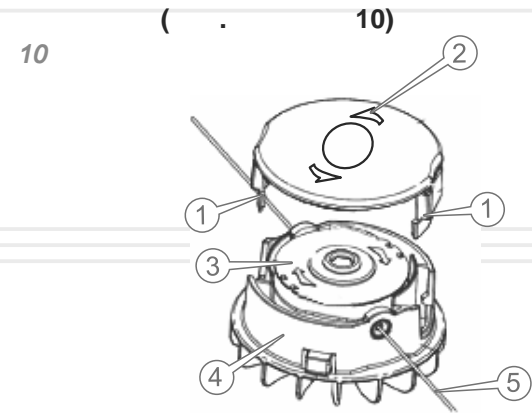

- 1.
- 2.
3. (3)
4. (4)
5. (5)
- 6.
- 7.
8. (1)
9. (2)
10. (1,2)

5



[Redacted text block]

6.  
7.

(6)



[Redacted text block]

УКРАЇНСЬКА



[Redacted text block] 10

8.  
9.

(7)



[Redacted text block] 15-17

10.

90%.

-15°

+55°

90%.

-15°

+55°



[Redacted text block]



3( )

Vitals Master EZT 032m

1( )

3( )

3( )

УКРАЇНСЬКА

УКРАЇНСЬКА



[Redacted text block]

- 
- 
- 
- 
- 
- 
- 

( )



- - 
  - 
  - 
  - 
  - 
  -
- . .).

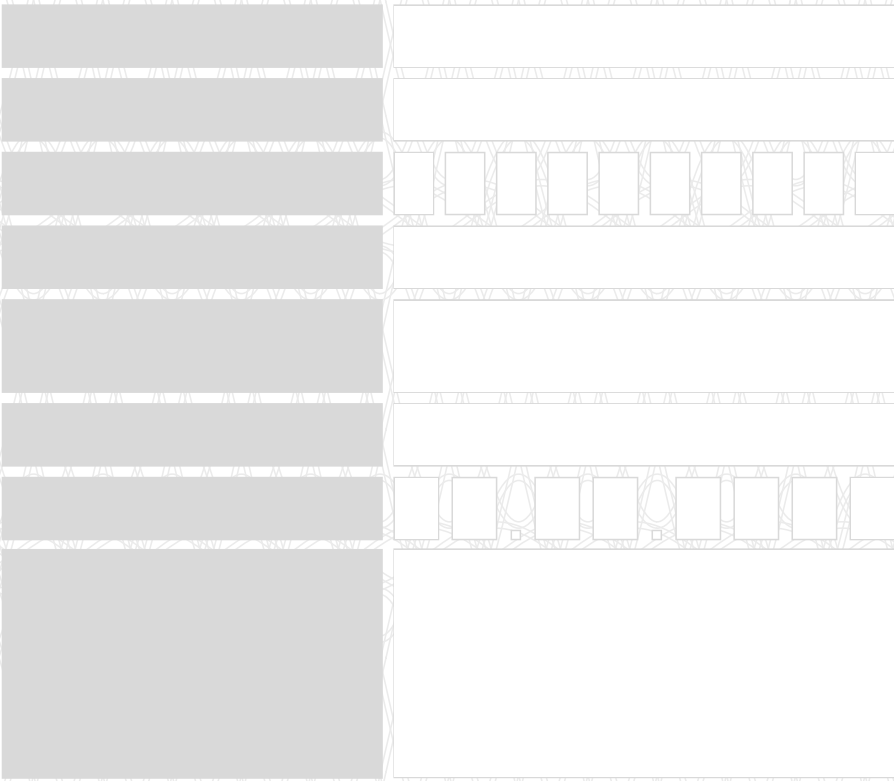
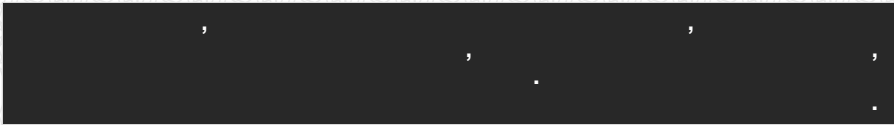

( ):

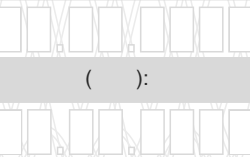

( )



( ):

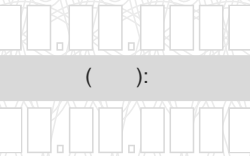

( )



( ):

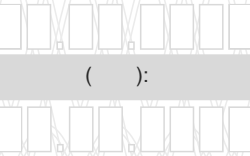

( )

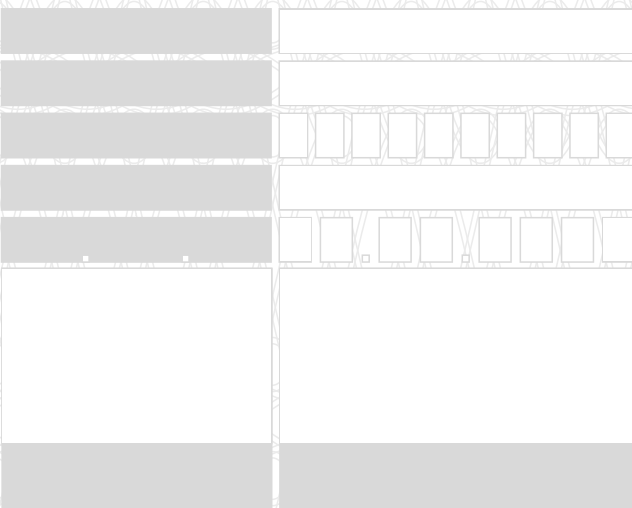
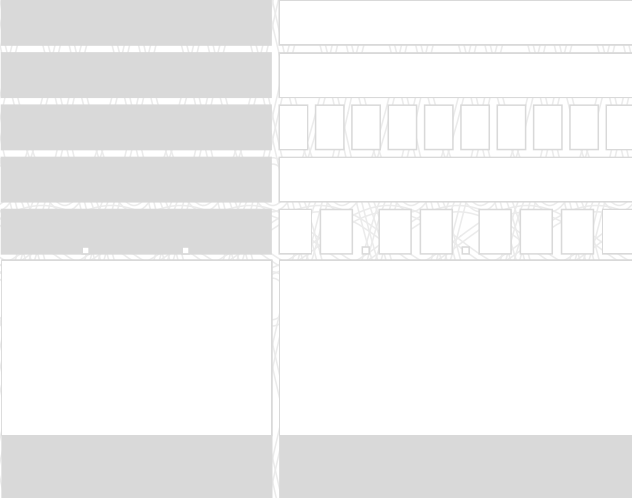
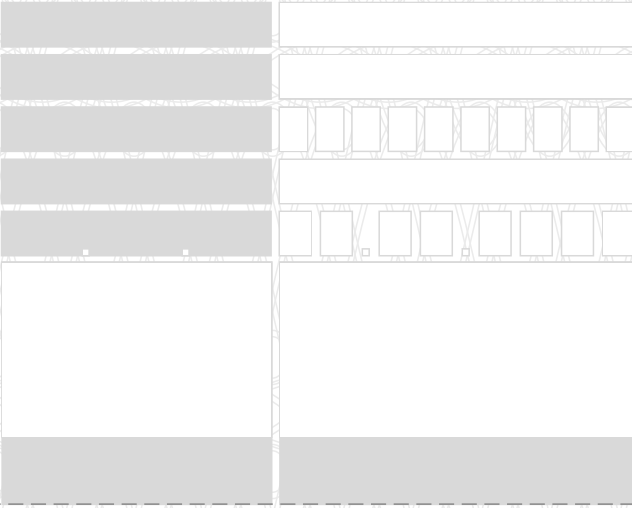

ВІДРИВНИЙ ТАЛОН

ВІДРИВНИЙ ТАЛОН

ВІДРИВНИЙ ТАЛОН

A horizontal form with a black border. It contains three white rectangular input fields of varying widths. A small grey dot is positioned above the first field, and a small grey comma is above the last. Below the fields, there are three small grey dots. A grey shadow is cast below the form.

A horizontal form with a black border. It contains three white rectangular input fields of varying widths. A small grey dot is positioned above the first field, and a small grey comma is above the last. Below the fields, there are three small grey dots. A grey shadow is cast below the form.

A horizontal form with a black border. It contains three white rectangular input fields of varying widths. A small grey dot is positioned above the first field, and a small grey comma is above the last. Below the fields, there are three small grey dots. A grey shadow is cast below the form.



?					

